

PAINTING GUIDE

To achieve the best results we recommend that the products be spray painted to match the adjoining ceiling colour.

If spraying is not possible, the products should be painted with a small foam roller, using thin regular paint rather than thick cutting-in paint.

Hand sanding between coats is essential.

Light incident on the curved surface will emphasize brush-marks so it is important that the finish be absolutely smooth.

FIXING GUIDE

'PHOENIX' is a recessed downlight specifically designed to be flush joined with plasterboard ceiling linings.

The 'PHOENIX' range of Morphers may be installed to steel or timber framed ceilings. No extra framing is required.

Sheet the entire ceiling before cutting a circular opening 2mm larger than the protruding rim of the Morpher.

Cut two slots diametrically opposite each other to allow the fixing flange to be slipped through and the whole unit to be pushed through to the ceiling void.

IMPORTANT

For use with 10mm or 13mm plasterboard. The plasterboard thickness must be specified at the time of ordering as the fixing flange is not adjustable.

Position the Morpher into the opening and screw fix through the surrounding plasterboard and metal flange at maximum 75mm centres with self-tapping plasterboard screws.

**during installation, pull electrical cable through the opening in the PHOENIX 350.*

ELECTRICAL

PX218M	VS Magnetic 2 x 18W non dimmable ballast
PX218E	VS Electronic 2 x 18W " "
PX226M	VS Magnetic 2 x 26W " "
PX226E	VS Electronic 2 x 26W " "

Pack the joint with cornice cement. Finish with top coat. Paint to match surrounding ceiling, hand - sanding between coats to achieve a perfectly seamless appearance.

After painting, the control gear and lampholder are to be fitted by a licensed electrician .

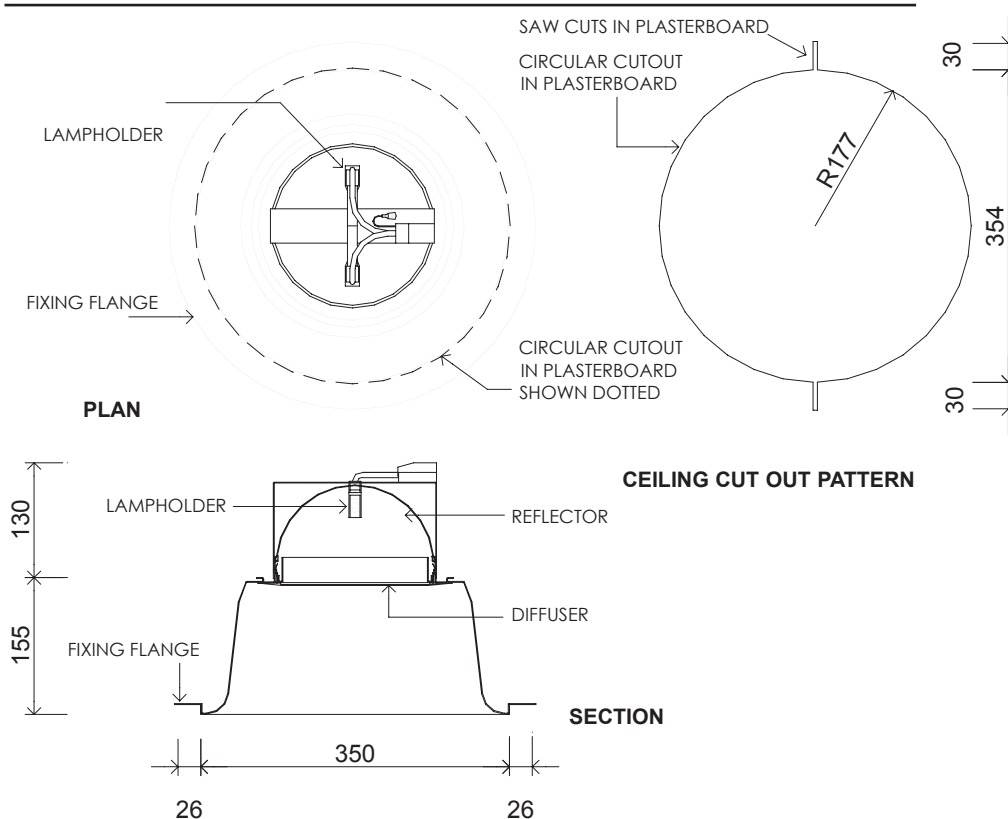

PAINTING GUIDE

To achieve the best results we recommend that the products be spray painted to match the adjoining ceiling colour.

If spraying is not possible, the products should be painted with a small foam roller, using thin regular paint rather than thick cutting-in paint.

Hand sanding between coats is essential.

Light incident on the curved surface will emphasize brush-marks so it is important that the finish be absolutely smooth.

FIXING GUIDE

'PHOENIX' is a recessed downlight specifically designed to be flush joined with plasterboard ceiling linings.

The 'PHOENIX' range of Morphers may be installed to steel or timber framed ceilings. No extra framing is required. Sheet the entire ceiling before cutting a circular opening 2mm larger than the protruding rim of the Morpher.

IMPORTANT

For use with 10mm or 13mm plasterboard. The plasterboard thickness must be specified at the time of ordering as the fixing flange is not adjustable.

Cut two slots diametrically opposite each other to allow the fixing flange to be slipped through and the whole unit to be pushed through to the ceiling void.

Position the Morpher into the opening and screw fix through the surrounding plasterboard and metal flange at maximum 75mm centres with self-tapping plasterboard screws.

**during installation, pull electrical cable through the opening in the PHOENIX 350.*

ELECTRICAL

PX70MH	VS 70W transformer & metal halide lamp
PX150MH	VS 150W transformer & metal halide lamp
PX100 LH	100W fitting & lineal halogen lamp
PX200LH	200W fitting & lineal halogen lamp

Pack the joint with cornice cement. Finish with top coat. Paint to match surrounding ceiling, hand - sanding between coats to achieve a perfectly seamless appearance.

After painting, the control gear and lampholder are to be fitted by a licensed electrician .

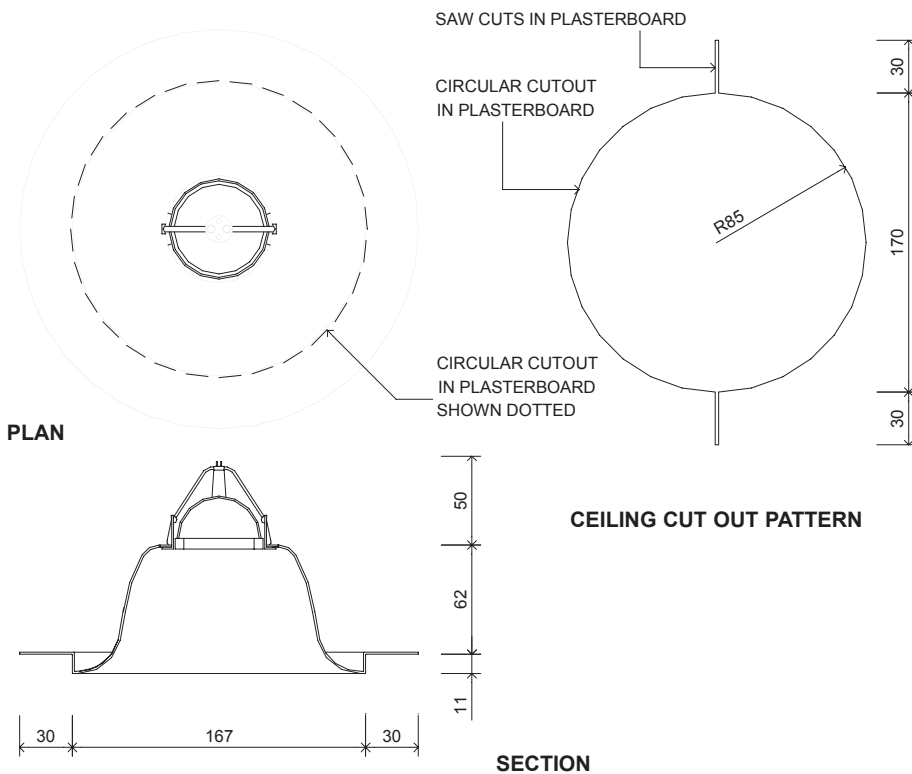

PAINING GUIDE

To achieve the best results we recommend that the products be spray painted to match the adjoining ceiling colour.

If spraying is not possible, the products should be painted with a small foam roller, using thin regular paint rather than thick cutting-in paint.

Hand sanding between coats is essential.

Light incident on the curved surface will emphasize brush-marks so it is important that the finish be absolutely smooth.

FIXING GUIDE

'PHOENIX' is a recessed downlight specifically designed to be flush-jointed with plasterboard ceiling linings.

The 'PHOENIX' range of Morphers may be installed to steel or timber framed ceilings. No extra framing is required.

Sheet the entire ceiling before cutting a circular opening 2mm larger than the protruding rim of the Morpher.

Cut two slots diametrically opposite each other to allow the fixing flange to be slipped through and the whole unit to be pushed through to the ceiling void.

Position the Morpher into the opening and screw fix through the surrounding plasterboard and metal flange at maximum 75mm centres with self-tapping plasterboard screws.

**during installation, pull electrical cable through the opening in the PHOENIX 165.*

Pack the joint with cornice cement. Finish with top coat. Paint to match surrounding ceiling, hand - sanding between coats to achieve a perfectly seamless appearance.

After painting, the control gear and lampholder are to be fitted by a licensed electrician .

IMPORTANT

For use with 10mm or 13mm plasterboard. The plasterboard thickness must be specified at the time of ordering as the fixing flange is not adjustable.

ELECTRICAL

PX12V M	50W magnetic ATCO LVL series transformer and lamp
PX12V E	60W electronic ATCO 'possum' transformer and lamp

1 FORM OPENING

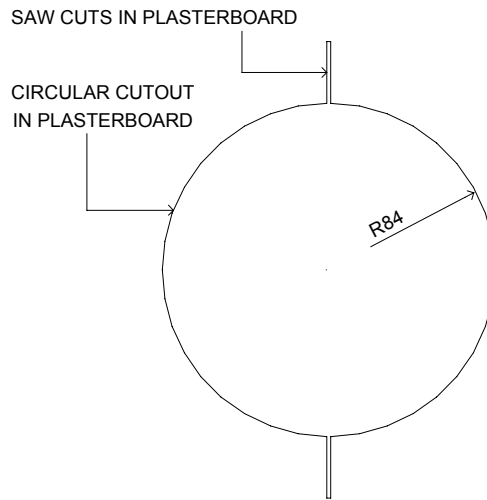

PLAN

2 PASS MORPHER THROUGH OPENING TO VOID BEYOND

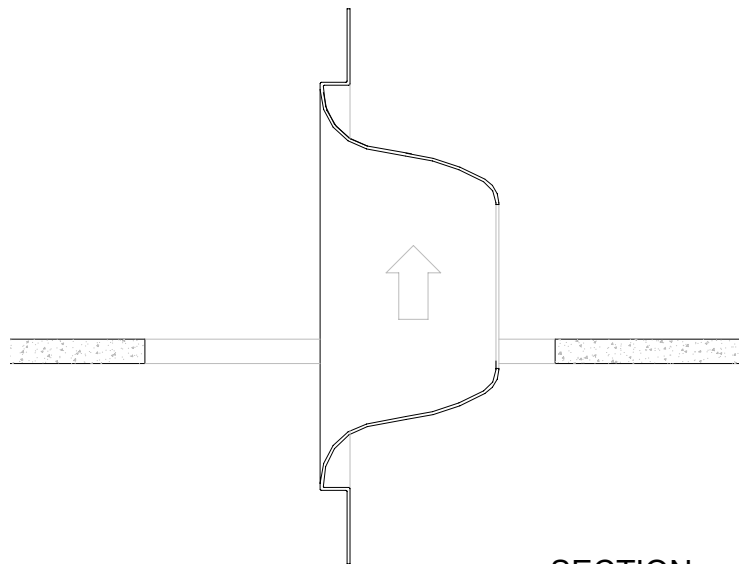

SECTION

3 POSITION MORPHER IN OPENING AND SCREW-FIX THROUGH CEILING LINING

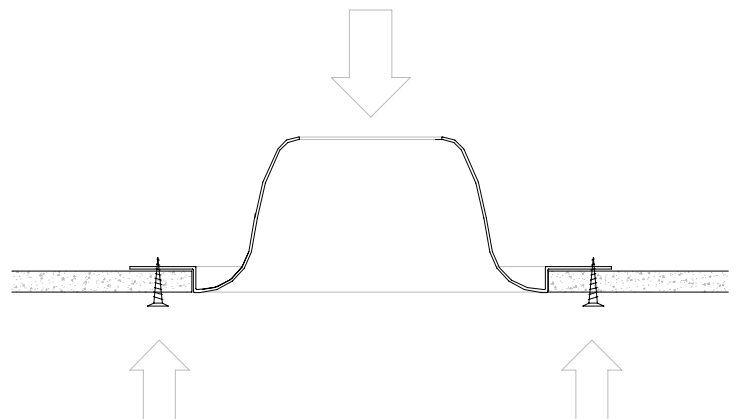

SECTION