

# M100 CASSETTE

- PENDANT OR SURFACE MOUNTED LUMINAIRE
- **m-SYSTEM**: CUSTOMER SPECIFIES LENGTH OF MODULE
- DIRECT AND DIRECT / INDIRECT
-  SATIN FINISH PARABOLIC LOUVRE – SUITABLE FOR VDU WORKSPACES ( $L < 1000 \text{ CD/M}^2$  FOR  $\text{GAMMA} \geq 65^\circ$ )
- DIMMABLE VERSIONS ON REQUEST
- SQUARE-EDGED EXTRUDED ALUMINIUM
- END CAPS OF DIE-CAST ALUMINIUM
- SILVER FINISH

## M100 PARABOLIC DIRECT



## M100 PARABOLIC DIRECT / INDIRECT



### M100 PARABOLIC DIRECT

		SILVER	L	B	H	P	W	DATA
1 x 54W	single length	<b>SX 709 013 154</b>	1196	100	100	900	5.6kg	3022
1 x 80W	single length	<b>SX 709 013 180</b>	1496	100	100	1200	7.0kg	3022
2 x 1 x 54W	double length	<b>SX 709 023 154</b>	2376	100	100	1040	11.2kg	3022
2 x 1 x 80W	double length	<b>SX 709 023 180</b>	2976	100	100	1340	14.0kg	3022
1 x 80 / 54 / 39W	<b>m</b> -System	<b>SX 70051-973-3</b>	var.	100	100	var.	4.7kg/m	3022
2 x 35 / 28 / 21W	<b>m</b> -System	<b>SX 70054-973-3</b>	var.	100	100	var.	4.7kg/m	3023



### M100 PARABOLIC DIRECT / INDIRECT

		SILVER	L	B	H	P	W	DATA
1 x 54W	single length	<b>SX 708 013 154</b>	1196	100	100	900	5.6kg	3042
1 x 80W	single length	<b>SX 708 013 180</b>	1496	100	100	1200	7.0kg	3042
2 x 1 x 54W	double length	<b>SX 708 023 154</b>	2376	100	100	1040	11.2kg	3042
2 x 1 x 80W	double length	<b>SX 708 023 180</b>	2976	100	100	1340	14.0kg	3042
1 x 80 / 54 / 39W	<b>m</b> -System	<b>SX 70151-973-3</b>	var.	100	100	var.	4.7kg/m	3042



LINEAR PENDANT AND SURFACE MOUNTED

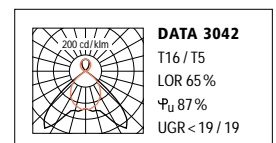
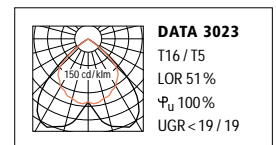
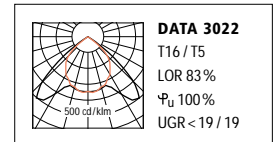
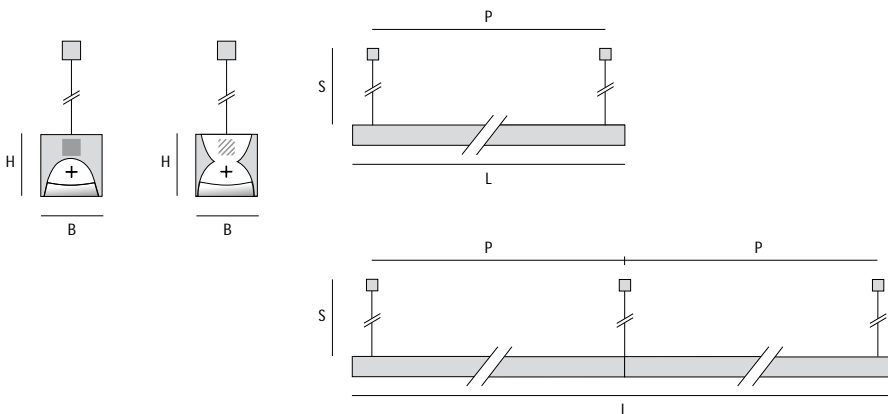

L: Length · B: Width · H: Height · P: Distance between suspension points · W: Weight · S: Suspension, 1500mm suspension can be cut on site

Dimmable versions for M100 DIRECT: .../04 = 1-10V · .../05 = DSI · .../06 = DALI

For **m**-system end caps and suspensions have to be ordered separately – see page 045





## M100 CASSETTE ACCESSORIES FOR -SYSTEM

### END CAP

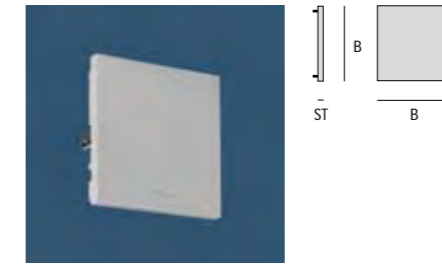

SILVER	B	ST
SX 99-443-3	100	8

### RECESSED DOWNLIGHT INFILL



SILVER	
SX 99-714-3	QPAR 16 lamp for mains voltage

### T MITRE

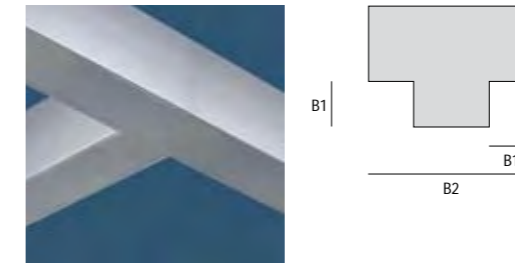

SILVER	B1	B2
SX 98-175-3	60	220

### L MITRE

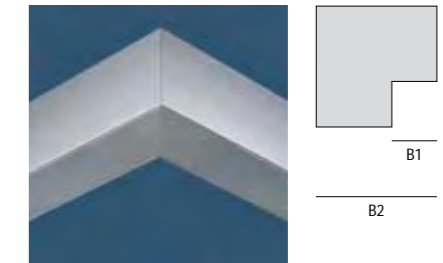

SILVER		B1	B2
SX 98-176-3	30°-180°	60	220

### MITRED END CUT

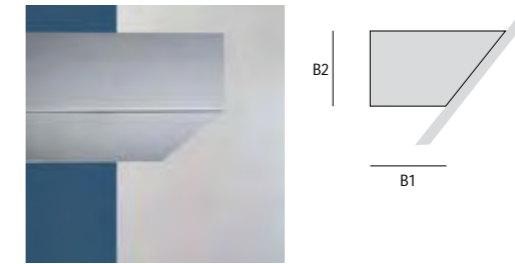

SILVER		B1	B2
SX 98-174-3	30°-180°	mind. 60	100

### X MITRE

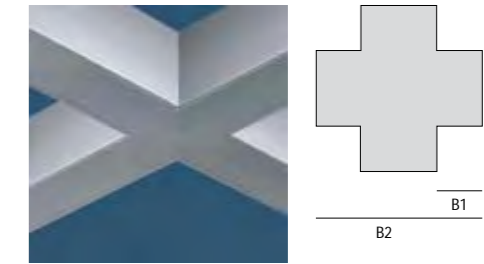

SILVER		B1	B2
SX 98-177-3		60	220

### PENDANT

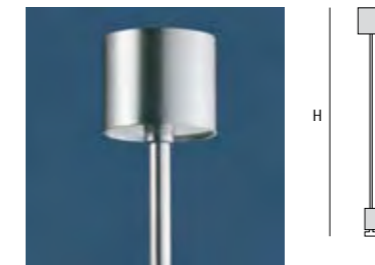

SILVER		Ø	H*
SX 99-820-3	pendant rod without feed	10mm	600
SX 99-821-3		10mm	1200
SX 99-833-3	pendant rod with feed (3 x 1.5 <sup>2</sup> )	10mm	600
SX 99-834-3		10mm	1200
SX 99-822-3	pendant rod without feed	13mm	600
SX 99-823-3		13mm	1200
SX 99-835-3	pendant rod with feed (5 x 1.5 <sup>2</sup> )	13mm	600
SX 99-836-3		13mm	1200

### WIRE SUSPENSION

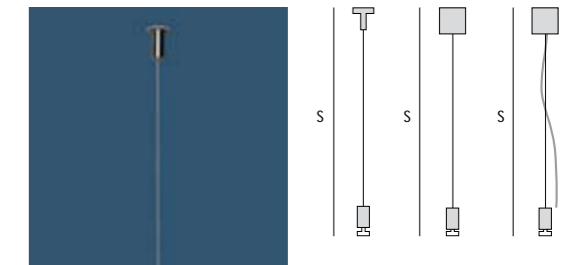

SILVER		S*
SX 99-830-3	with ceiling mounting	1500
SX 99-831-3		3000
SX 99-828-3	with canopy	1500
SX 99-829-3		3000
SX 99-824-3	with 3 core supply cable (3 x 0.75 <sup>2</sup> )	1500
SX 99-825-3		3000
SX 99-826-3	with 5 core supply cable (5 x 1.5 <sup>2</sup> )	1500
SX 99-827-3		3000

B: Width · ST: Thickness · Ø: Diameter · H: Pendant rod length · S: Wire suspension length  
\* can be cut on site