



## SATINLIGHTS® OFFICE

- PENDANT OR SURFACE MOUNTED LUMINAIRE
- PENDANT AS INDIVIDUAL AND DOUBLE LUMINAIRE
- DIRECT / INDIRECT
- MICROPRISMATIC MULTILAYER DIFFUSER
-  SUITABLE FOR VDU WORKSPACES (L<1000 CD/M<sup>2</sup> FOR GAMMA≥65° RADIALLY AROUND)
- LIGHT MANAGEMENT USING CLT: PROVIDES CONSTANT LUMINANCE OVER ENTIRE LAMP LIFE
- SQUARE-EDGED EXTRUDED ALUMINIUM
- 35MM STEPPED LOW PROFILE
- SILVER FINISH GLOSS ANODISED

### SATINLIGHTS® OFFICE PENDANT LUMINAIRE

### SATINLIGHTS® OFFICE SURFACE LUMINAIRE



### SATINLIGHTS® OFFICE PENDANT LUMINAIRE

		ANODISED	L	B	H	P	W	DATA
2 x 28W	single length	<b>SX 742 013 228</b>	1233	260	50	1214	4.9kg	4382
2 x 2 x 28W	double length	<b>SX 742 023 228</b>	2466	260	50	1214	9.6kg	4382
2 x 54W CLT*	single length	<b>SX 742 013 254/08</b>	1233	260	50	1223	6.1kg	4387
2 x 2 x 54W CLT*	double length	<b>SX 742 023 254/08</b>	2466	260	50	1223	11.9kg	4387



### SATINLIGHTS® OFFICE SURFACE MOUNTED LUMINAIRE

		ANODISED	L	B	H	M	W	DATA
2 x 28W CLT*		<b>SX 741 013 228/08</b>	1239	260	50	1000	5.1kg	4386
2 x 35W CLT*		<b>SX 741 013 235/08</b>	1539	260	50	1000	6.3kg	4386

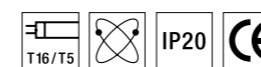
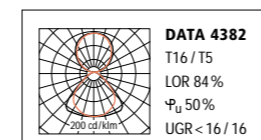
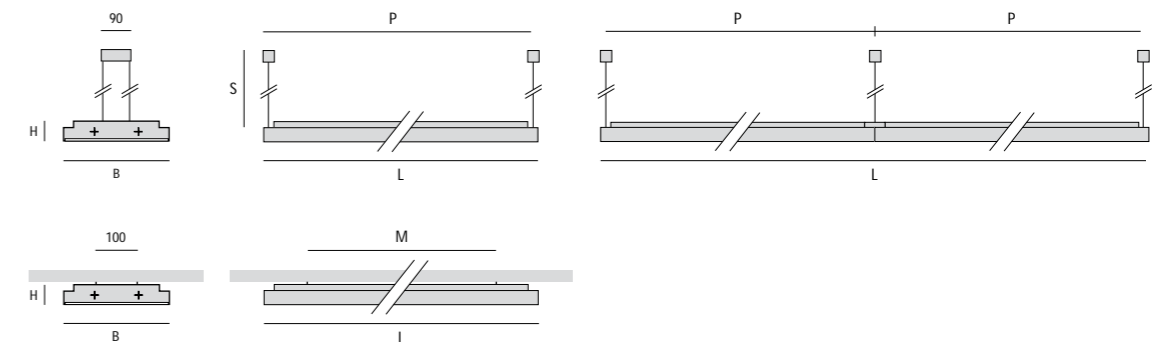

L: Length · B: Width · H: Height · P: Distance between suspension points · M: Distance between fixation points · W: Weight · S: Suspension. 1500mm suspension can be cut on site  
 Alternative dimmable versions: .../04 = 1-10V · .../05 = DSI · .../06 = DALI · Additional photometrics on request

\*CLT Technology is an autoadjusting electronic device for constant luminance over entire lamp life, see page 230