

LASER Exterior Step Lite Louvre



The Step Lite Louvre has a flush to the surface look with no protrusions. The 45 degree louvre eliminates all upward light, making this luminaire ideal for providing illumination of steps and low level features such as exterior paved areas.

A 110/240 volt fluorescent option is available which offers excellent light output, low energy usage and very low heat generation, this changes the luminaire to an IP66 rating.

Step Lite Louvre

Cat. No. SLLU
Cat. No. SLLUfl

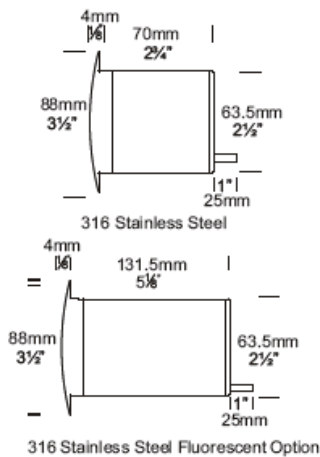

316 Stainless Steel Fluorescent Option

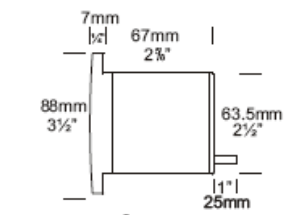

Copper

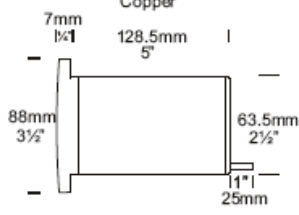

Copper Fluorescent Option

Ordering Information

Luminaire Type	Material	Accessories
SLLU - Step Lite Louvre	COP - Copper SS - 316 Stainless Steel	CJK150 - Cable Joint Kit FL - Fluorescent Option LENSSTEPF - Frosted Lens Flucan - Fluorescent Canister PVC Slican - Step Lite Canister Canss - 316 Stainless Steel Canister For an alternative LED option start at page 10.4

Ordering Example SLLU COP - Step Lite Louvre in Copper
SLLUFL SS - Step Lite Louvre in 316 Stainless Steel with fluorescent option

LENSSTEPF - Frosted Lens
(Accessories ordered separately)

Luminaire Construction
CNC machined from one of the following metals:
Copper: 63.5mm (2 1/2") x 10mm (13/32"). End cap - solid copper 63.5mm (2 1/2") rod. Flange 88mm (3 1/2") solid copper rod.
316 Stainless steel: 9mm (11/32"). End cap - solid 316 stainless steel 63.5mm (2 1/2") rod. Flange 88mm (3 1/2") solid 316 stainless steel rod.

Mounting
Designed to fit through a 66mm (2 5/8") hole and be fixed into position by two screws in the flange or a Step Lite canister (see accessories) can be used which maintains the aesthetic look of the flange by eliminating the two screw holes in the flange.

Features
Lens:
3mm (1/8") thick clear tempered shatter resistant glass.
Life Time Warranty.
Gaskets:
Silicone, iron impregnated 220°C (428°F).
Lamp Holders:
GU 5.3 - 350°C (662°F) ceramic multi contact lamp holder with 250°C (480°F) teflon cables.
Fluorescent:
E27 PET 210°C (410°F) base mount. E26 available in the USA.
Accessories:
Cable Joint Kit (Cat. CJK150). Not approved for USA/Canada.
Frosted Lens (Cat. LENSSTEPF).
Fluorescent Canister, PVC (Cat. Flucan).
Fluorescent Option 8watt 240volt (Cat. FL) IP66.
Step Canister (Cat. Slican).
316 Stainless steel Canister for use in lime stone etc. (Cat. Canss).